

Magnetic stirrer seals type MRK 1 and MRK 2



KGW-ISOTHERM

Gablonzer Straße 6
76185 Karlsruhe
Germany

Tel: 0049 / 721 95897-0

Fax: 0049 / 721 95897-77

Internet: www.kgw-isotherm.de

e-mail: info@kgw-isotherm.de



11.09.2007

User's manual MRK 1 and MRK 2

Table of contents

1. Operation description	page 1
2. Usage according to regulations	page 1
3. Security advices	page 2
4. Starting operation	page 2
5. Maintenance	page 2
6. Dysfunctions	page 2
7. Technical data	page 3
8. Accessory	page 3
9. Overview drawing	page 5
10. Detailed drawing	page 6

1. Operating description for magnetic stirrer seals made of stainless steel

Magnetic stirrer seals are equipped with permanent magnetic coupling and depending on type are manufactured of the materials no. 1.4435, 1.4541 and 1.4980. The performance of seal must be chosen due to the viscosity and the volume of medium that is to stir. They can operate with every stirring machine up to a maximum rotation speed of 2500 turns per minute. They are absolutely gas-proof and vacuum-proof. The chemical resistance corresponds to the general valid resistance lists of material manufacturers. A lead through shaft as well as its sealing by squeezing rings drops, as the forces are transmitted by magnets. The drive shaft and the driven shaft are equipped with ball bearings whereby the stirring machine is hardly loaded.

2. Usage according to regulations

Magnetic stirrer seals are suitable for all stirrer functions in laboratories or factories. The types MRK 1 (NS29/32) and MRK 2 (NS45/40) are produced with NS standard ground joint or flange so that they especially suit to operation with pressure-less glass devices. The flange version out of stainless steel can be used by choosing an adequate pressure level for devices up to 10 bars.

Attention!!!

KGW Isotherm disclaims any liability for alterations at the above-mentioned devices executed without previous consultation and written confirmation of KGW Isotherm.

3. Security advices

- a) MRK magnetic stirrer seals out of stainless steel can be used up to a maximum speed of 2500 turns per minute and a temperature range up to a maximum of 300°C.
- b) Types MRK 1 and MRK 2 with NS standard ground joint can only be used for vacuum range or pressure-less applications.
- c) The stainless steel flange construction is operational in vacuum range and, depending on type and material, for pressure-less, respectively devices up to 10 bars.
- d) The connection between MRK and stirring machine has to effect by an adequate flexible coupling.
- e) Reparations have to be executed by experts.
- f) Only KGW original spare parts are to apply.

4. Starting operation

The MRK magnetic stirrer seals may only be applied to indicated purposes. The preset security advices and regulations are to be observed and followed.

5. Maintenance

- Before any maintenance work, the seal has to be disconnected from stirrer machine and vessel.
- Types MRK 1 and MRK 2 should be removed from the lid, before cleaning.
- The positioning of the drive shaft and the driven shaft should be checked at regular intervals.
- After the stirring process, the interior parts should be cleaned of potential residues of the product.
- Depending on type, check o rings and gaskets for visible damages.
- The non-application of original parts effects the warranty service to be void.
- Reparations are to be executed by skilled staff only. For questions, please contact KGW Isotherm or authorised specialist dealer.

6. Dysfunctions

Dysfunctions of magnetic stirrer seals can have the following causes:

- a. The bearing is defect.
- b. Soiling of interior by residues.
- c. Gasket seal is defect.
- d. Damaged magnets caused by hydrogen.

7. Technical data

For technical data, please refer to attached indication, by choosing the desired type.

Type	Joint	Torque	Viscosity	Volume
MRK 1/40	NS 29/32	40 Ncm	2500mPas	4000ml
MRK 1/60	NS 29/32	60 Ncm	3500mPas	6000ml
MRK 1/90	NS 29/32	90 Ncm	4000mPas	10000ml
MRK 1/120	NS 29/32	120 Ncm	Technical data on request.	
MRK 2/40	NS 45/40	40 Ncm	2500mPas	4000ml
MRK 2/60	NS 45/40	60 Ncm	3500mPas	6000ml
MRK 2/90	NS 45/40	90 Ncm	4000mPas	10000ml
MRK 2/120	NS 45/40	120 Ncm	Technical data on request.	

8. Spare parts / accessory

For accessory of the MRK magnetic stirrer seals, please refer to attached, marked accessory list.

MRK 1 crank pine
MRK 1 Spare o ring for NS 29/32
MRK 1 Spare Rulon ferrule 8 mm
MRK 1 Spare Rulon ferrule 10 mm

MRK 2 crank pine
MRK 2 Spare o ring for NS 45/40
MRK 2 Spare Rulon ferrule 8 mm
MRK 2 Spare Rulon ferrule 10 mm

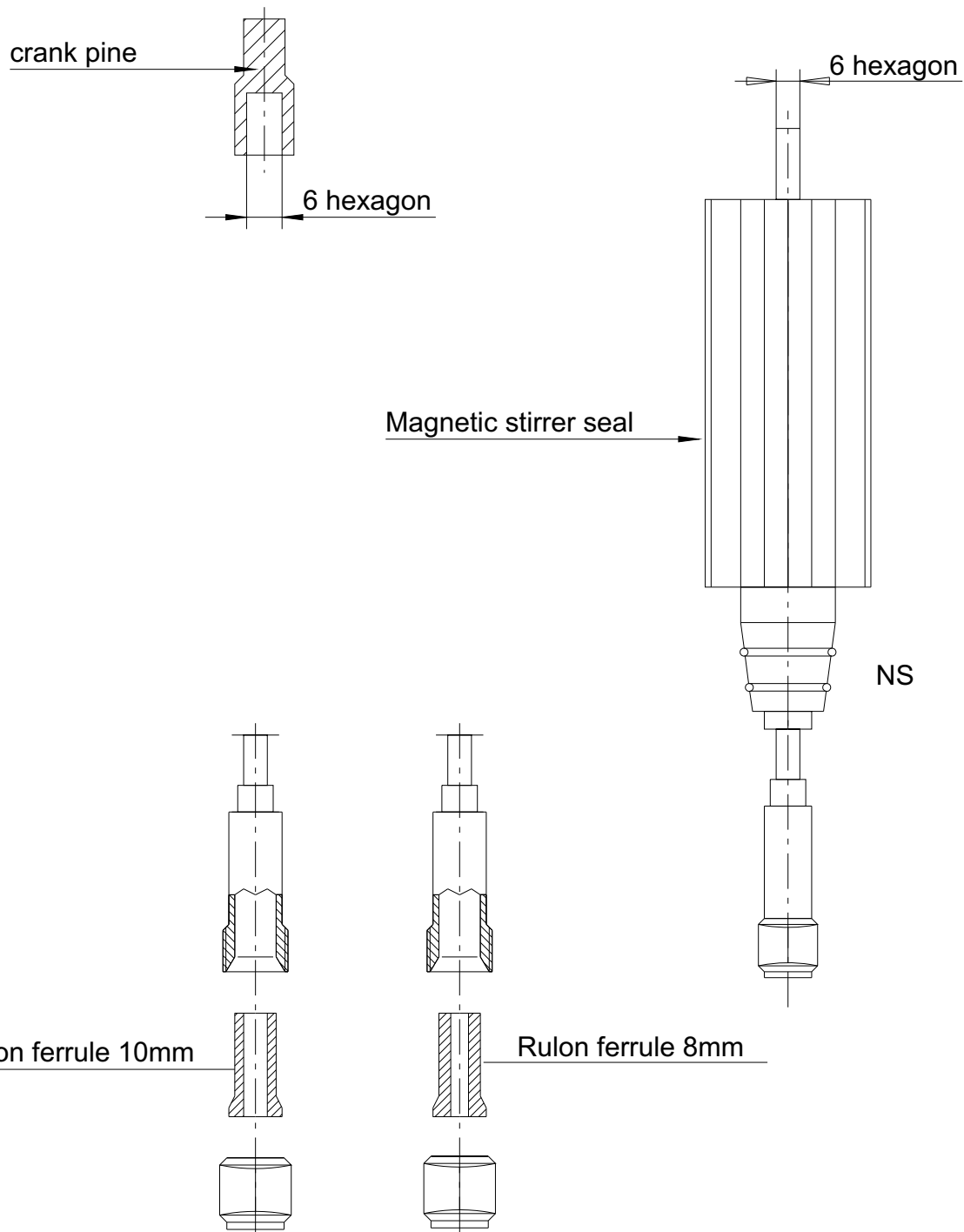

Diese Zeichnung darf ohne Genehmigung weder vervielfältigt noch an dritte Personen weitergeleitet werden

geändert Datum	Name	Maße und Toleranzen, wenn nicht näher spezifiziert, unterliegen den Eigenarten und Besonderheiten der Glasverarbeitung und werden dem Stand der Technik entsprechend realisiert.		KGW-ISOTHERM 76185 Karlsruhe Tel.0721/958970 Fax.0721/9589777
		Tag: 06.09.2007	Name: Schieder	Magnetic stirrer seals type MRK 1 and MRK 2
		Maße: mm	unmaßstäblich	
		Werkstoff: Edelstahl	Z.Nr:Mag.Rührkupplung Handbuch E	

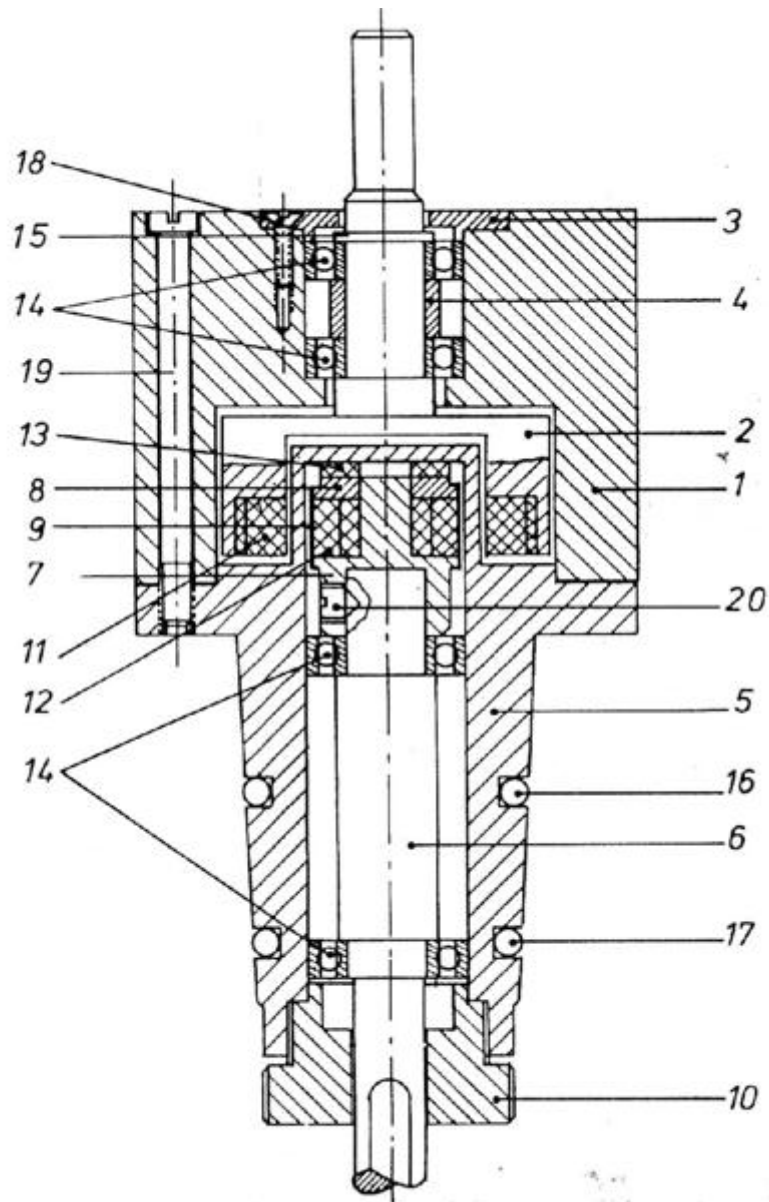

Pos.	piece	part name
1	1	casing
2	1	socket
3	1	cap
4	1	bushing
5	1	cone
6	1	shaft
7	1	magnet support
8	1	front ring
9	1	protective casing
10	1	fastener
11	1	solenoid drive
12	1	solenoid driven
13	1	pulley
14	4	ball bearing, 16 x 8 x 4
15	1	retailing ring
16	1	Viton o ring 21 x 3
17	1	Viton o ring 20 x 3
18	3	counter sunk screw M2 x 5
19	3	counter sunk screw M3 x 45
20	1	setscrew M5